

TERRATRIP

CHOSEN WHEN SUCCESS IS IMPORTANT

Tripmeters - Fitting and Operating Instructions

Thank you for purchasing this product, with care the unit should give you good service. **Please** read these instructions carefully, by doing so you will get full use of the unit and save yourself a great deal of frustration.

Installation and use

The procedure for use and installation are:-

1. Install the probe and Rally Computer.
2. Test that the probe is working i.e. making the Rally computer count distance.
3. Calibrate the Rally Computer to suit your car for miles or kilometres readout.

IMPORTANT NOTE: There are no customer serviceable parts in this unit. If you open the case you may damage the connection to the keyboard, if so then the keyboard may have to be changed and this will be at your cost. **These units do not have an internal battery.**

T 202 PLUS has only distance and speed functions. Button SPD makes the display show Speed and Total distance.

OPERATING

When the unit is switched on it will display the information which was on the display when the unit was last switched on. The unit remembers Time of Day, Stopwatch, Total and Interval Distances. If you wish to zero all of this information then press the '0' key for 3 seconds.

Tripmeters –

Fitting and Operating Instructions

GENERAL

Keep the probe and cables away from the car's H.T. circuits and/or electronic ignition and alternator cables.

Protect the probe/cable from damage by stones, etc., e.g. cover with flexible plastic tubing; it is generally safer, where possible, to fit the probe to the rear (trailing) of the vertical centre line of the wheel assembly. Do not over tighten the probe locknuts. Make sure that the electrical connections at the terminal strip, on the instrument are tight. If you lose or damage any of the three M5 mounting screws do not replace with screws longer than 10mm or you may short out and damage the internals of the electronics unit. Before switching on the electrical supply to the unit make absolutely sure you have made the correct connections at the terminal bar.

STANDARD PROBE-FITTING

Position the probe such that it 'looks' at the bolt heads, which secure the brake disc to the hub of a non-driven wheel – see drawing.

In some cases it may be convenient to look at the holes in the metal surface. The probe should be co-axial with the centre line of the bolts, and the front face of the probe must be parallel with the heads of the bolts. Ideally any indentations or other markings on the bolt heads should be removed but care must be taken to ensure that the fitted heights of the bolt head are the same for each wheel set. Remove dirt, rust and grease accumulations from the inner face of the disc/hub assembly.

Screw in the probe until it just touches the head of one of the bolts and then turn it out 1 to 1.75 turns. Tighten the locknut to a maximum torque of 5 ft lbs. Run the probe cable up to the electronic unit.

The thread of the unit is an uncommon size (M14 x 1), you may therefore find it useful to weld/braze the nut to a small plate and then screw or rivet the plate to the probe support bracket. If this is done then it is easy to remove the probe fixing nut from one suspension unit to another.

NB If you weld/braze one of the probe nuts to the bracket or brake back plate for a fixing DO NOT UNDER ANY CIRCUMSTANCES use the probe to hold the nut whilst welding.

TYPICAL PROBE INSTALLATION

1. The bolt head must be steel. The probe will sense aluminium but the sensing distance is reduced by 50%.
2. Cup head bolts are not suitable targets for the probe to sense from.
3. The bolt head must be at least 80% of the diameter of the probe.

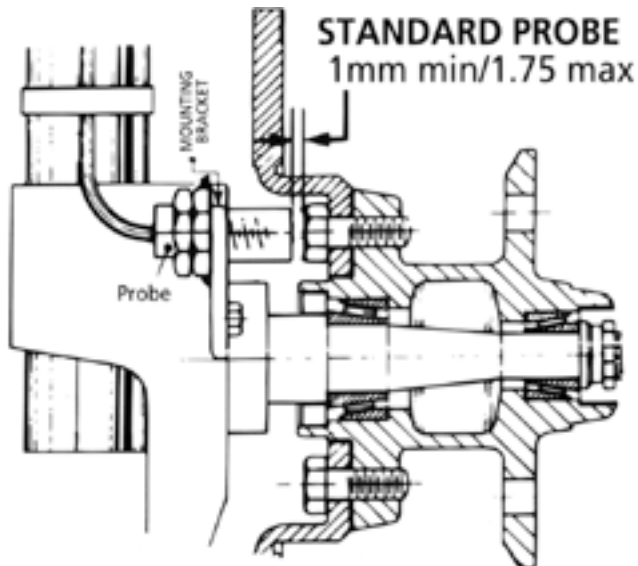

Cable Drive Probes – Fitting

JAPANESE CABLE DRIVE PROBES

These probes fit most Japanese and some American cars. Push forked peg into probe from end of probe with ring nut, push square peg into probe from other end so that it engages into fork peg. The probe is screwed onto the gearbox between the gearbox and the speedometer cable. Tighten by hand NOT with a wrench.

UNIVERSAL CABLE DRIVE PROBES

This probe is designed to fit all cars. Remove the inner cable and cut out 40mm (1 1/2 inches) section from the outer cable. Put the metal sleeves and ring nuts over each cable end. Push the inner cable through one outer half and through sensor. Put inner cable through other outer cable; tighten the 2 rotor screws onto inner cable. Fasten ring nuts.

The sensor is designed for inner cables of 3.2mm (1/8 inch). If your cable is larger remove the two rotor screws and fit a M2.5 screw in one of the rotor screw holes. Carefully drill out the rotor to the required size.

Some cars have an inner cable, which cannot be easily withdrawn.

If you cannot release the crimp that holds the inner cable into the outer cable proceed as follows: cut through both inner and outer cable. Carefully remove 20mm (3/4 inch) from each end of each outer cable half. Push sleeve and ring nut onto each end of outer cable. Push inner cable in to each end of sensor and tighten rotor screws.

ELECTRICAL CONNECTIONS

Terratrip 1

Black=Ov White=P- Orange=P+

Note this probe CANNOT be used on some early Terratrips where the voltage between P- and P+ is 8 volt. Use only on units where the voltage is 5 volts.

Terratrip 202/303

White=Pin 2 Orange=Pin 10 Black=Pin 11

(Note on Pin 11 you will also have car battery [-] connection).

IMPORTANT NOTE

The universal probe is not waterproof. Protect with fireproof and waterproof material if exposed to excess water. The probes should not be fitted close to the exhaust system, engine block. Upper temperature limit 125 Celsius.

ELECTRONIC UNIT

The electrical supply to the electronic unit MUST be fused (at no more than 2 amps). Use a line fuse, using a separate 12V feed from the remainder of the car's electrics – from a permanently available supply, (e.g. NOT ignition switch controlled).

It is generally best to take the supply direct from the battery terminals (*both positive and negative*). You must fit a line fuse immediately after the positive battery terminal (negative if you have a positive earth system). As all units have their own on/off switch we suggest that you do not fit an on/off switch in the tripmeter supply.

NOTE: Terratrip 1 is suitable for negative earth systems only. Terratrip 202/303 are suitable for both negative and positive earth systems.

ELECTRONICS ON/OFF

The electronics on/off switch on model T1 is marked I/O, I=on; O=off. On T202/T303 the electronics on/off switch is on the upper right hand side of the unit. When the switch is 'up' the electronics are 'off', and when the switch is 'down' the electronics are 'on'.

WHEN USING JAPANESE OR UNIVERSAL SPEEDOMETER PROBE

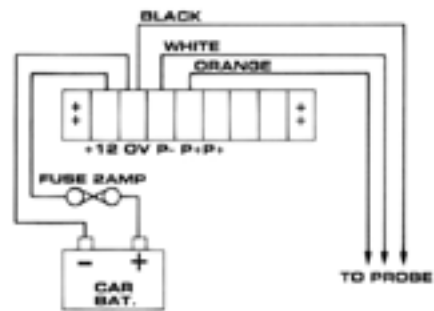

CONNECTION FOR 'TERRATRIP 1' STANDARD PROBE

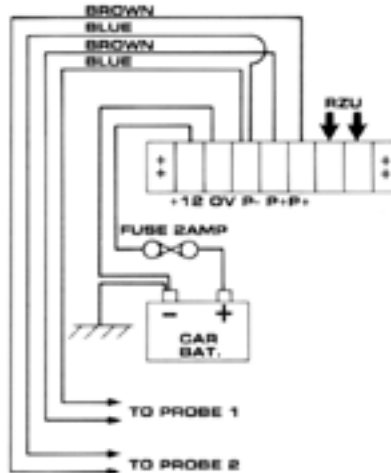

WHEN USING JAPANESE OR UNIVERSAL SPEEDOMETER PROBE

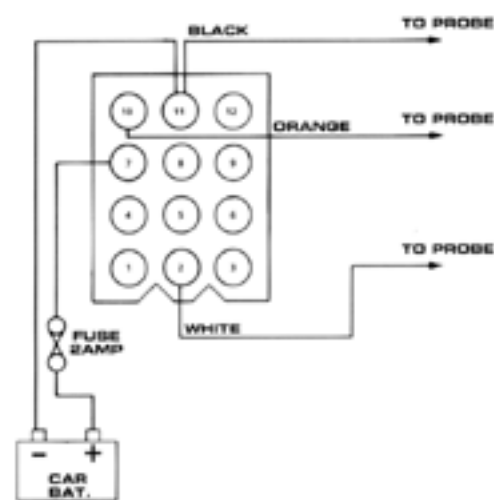

TERRATRIP 202/303/404 STANDARD PROBE

NOTE: Picture shown below is with white plug inserted into instruments. There are pin numbers on the white plug.

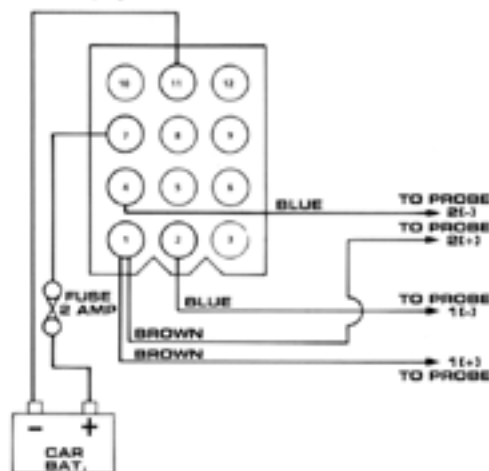

NOTE: Connections marked 'RZU' are for hand held Remote Zeroing Units. If you are using a foot operated Remote Zeroing Unit then connect the wires: Terratrip 202/303 to pins 5 and 8. For Terratrip 202/303 Plus connect to pins 5 and 12.

CALIBRATION—SETTING NUMBER

Terratrip 1

Set CAL switch to CAL, display shows C100. Press F and S to adjust hundreds, F to adjust tens, S to adjust units.

CALIBRATION NUMBER-CALCULATION

Terratrip 1

Set calibration to 10% of number of pulses probe gives per mile (for mileage readout) or per kilometre (for kilometre readout).

Terratrip 202 PLUS and 303 PLUS

Set Calibration Number to number of pulses probe gives per mile (for mileage readout) or per kilometre (for kilometre readout).

ALL MODELS

Set the Calibration Number to 100 (T1), or 0100 (T202PLUS/303PLUS) or 1000 for "HR" (Road Survey models). Exit from Calibration Mode so that displays are now showing Distance. Start with the Distance Displays at zero and run the car over a distance of 1 mile (1 kilometre if you want kilometres displayed). At the end of the run make a note of the number in the Interval Distance Display. Set the tripmeter to Calibration Mode and set the Calibration Number to the same number as was shown on the Interval Distance Display at the end of 1 mile (or 1 kilometre). Exit from Calibration Mode. The instrument is now calibrated.

DISTANCE SECTION CONTROLS

Terratrip 1

Press ZERO to zero display. Switch +/- makes display count up or down. Switch 1/0/2 selects which probe is to be used for distance sensing. The centre position of the switch – marked 0 – cuts out both probes.

To adjust the Distance Display press S to adjust the hundredths, F to adjust the tenths, F and S to adjust the units.

Terratrip 202 Plus and 303 Plus

Press FRZ. Upper display shows F. Both distance displays freeze. Internally Total carries on counting and Interval resets to zero and starts to count again. Press FRZ again and displays count normally.

MANUAL SETTING OF TOTAL DISTANCE -Terratrip 1

Press S to adjust hundredths, F to adjust tenths and F + S to adjust units.

Terratrip 202 Plus and 303 Plus CALIBRATION

Press CAL and the calibration number currently in use is shown. After 3 seconds display will revert to those shown before you pressed CAL. If you press CAL again, within 3 seconds, the other calibration number will be shown. If you do not wish to use this calibration number press CAL within 3 seconds and the original calibration number will be shown for 3 seconds. When the display shows the Calibration you wish to use do not press any key. After 3 seconds the calibration number will disappear and that number will be used by the unit. The display shows which calibration number is in use.

To change a calibration number display that calibration number by pressing CAL one or two times. Press CAL SET. Enter the calibration number you require and then press the lower CLR. If you make an error press the upper CLR and the number will revert to the original number. If you try to enter a number of less than 100 the display will show 'Error' and the bleeper sounds when the lower CLR is pressed. Enter a number equal to or greater than 100 and press the lower CLR to enter that number

DISTANCE SECTION

DIS. Makes the unit show Total and Interval distances.

+/-. When pressed unit changes between increasing and decreasing distance counting. A [-] sign is shown at the left side of the Total distance when the unit is decreasing distance counting.

FRZ. When pressed the displays freeze, 'F' is shown at the left of the Total distance. Internally the Interval distance is zeroed and re-starts counting, the Total continues to count. Press FRZ again and the displays count normally.

DIS SET. This allows you to pre-set a distance into the Total display. Press DIS SET and the Total display shows 0.00. Enter up to 5 digits, for the distance you wish to pre-set, then press the lower CLR. If you make a mistake with entering the correct number the press the upper CLR and start again.

Upper **CLR.** Press for 3 seconds to zero the Total display.

Lower **CLR.** Press to instantly zero the Interval display.

PROBE. Selects probe1, probe[s] off, probe 2[if fitted]. Display shows which, if any, probe is in use.

TIME SECTION

TIME. Press this key to enter Time Mode.

Upper display shows Time of Day up to 23:59:59

Lower display shows Stopwatch up to 59:59

1. Press lower CLR to start stopwatch.
 2. Press lower CLR to freeze stopwatch. Stopwatch continues to count internally.
 3. Press lower CLR again and the stopwatch shows the current Stopwatch time.
 4. Press lower CLR again to repeat [2] and [3] ad infinitum.
- Press lower CLR for 3 seconds to zero the stopwatch.

TIME SET. This is used to set the Time of Day. Press TIME SET and the upper display shows : : . Enter up to 4 digits for the Time of Day. Press the lower CLR and the time of Day will start. If you make a mistake then press the upper CLR and the Time of Day will revert to the time shown before you started to enter the Time of Day. If you try to enter an invalid time e.g.24:02:00 then when you press the lower CLR the display will show 'Error' and the bleeper sounds. The display will show you invalid time. Now enter a valid time and press the lower CLR.

UK TARGET TIMING

SW pressed	1	2	3
Stopwatch	Starts	Stop	Zeroed
Time of Day	Runs	Frozen	Rejoins real time
AV. Speed	Runs	Zeroed and restarted	Runs

CONTINENTAL TARGET TIMING

SW pressed	1	2	3	4	5
Stopwatch	Starts	Frozen	Rejoins	Stops	Zeroed
Time	Runs	Frozen	Rejoins real time	Frozen	Rejoins real time
AV. Speed	Zeroed and restarted	Runs	Runs	Runs	Runs

TSD SECTION

TSD. Press to enter TSD mode. There are three TSD modes.

TSD1. Upper display shows Stopwatch which operates in the same manner as in Time mode. Stopwatch is controlled by the upper CLR. The lower display shows Interval distance and is controlled by the lower CLR.

To change from TSD1 to TSD2 press TSD key for 3 seconds.

TSD2. As TSD 1 except upper display shows Time of Day.

To change from TSD2 to TSD3 press TSD for 3 seconds.

TSD3. Upper display shows Total distance lower display shows Speed.

To change from TSD3 to TSD4 press TSD for 3 seconds. Upper display shows Average Speed. Lower display shows Interval Distance. Average Speed is zeroed when either FRZ pressed or Stopwatch zeroed.

To change from TSD4 to TSD1 press TSD for 3 seconds

DISPLAY TEST.

Press DIS then press '+/-' for 3 seconds to enter this mode. Press any key to exit this mode.

INTERNAL BATTERY –T1 only

This is a Nickel Cadmium rechargeable type and **MUST NOT** be replaced with any other type of battery. If you use other than Nickel Cadmium batteries at best you will damage the unit and at worst you may cause yourself personal injury when the battery explodes!

INSTRUMENT MOUNTING

Liquid Crystal Displays have a finite viewing angle, therefore to get maximum visibility the instrument should be mounted so that the co-driver can look at the displays at an angle of 90° in both the vertical and horizontal planes. When viewed from angles of more than ± 20° the display contrast may be reduced.

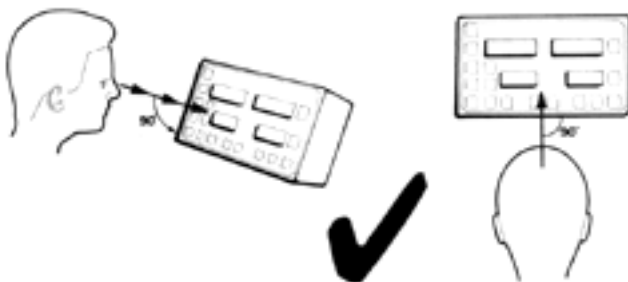

Additional Notes for Users

The following notes are provided for your assistance.

We suggest that you read the notes thoroughly before installing your instrument.

Probes

Wheel mounted probes – mounting

The most likely cause of failure of this type of probe is damage caused by stones or by the electrical cable being allowed to flex at the point where the cable enters the probe. This problem is easily overcome as follows:

Get a rubber sheath of the type which are fitted on the ends of H.T. distributor leads. Put the sheath over the probe lead and push it over the end of the probe. The rubber sheath should be secured in position using plastic 'Ty-Raps' (or similar from such manufacturers as Panduit, etc).

We also recommend that you use a strong steel bracket, minimum thickness 3mm to hold the probe in position. Check the probe gap with the car 'on the road'.

Speedometer cable probes – mounting

This type of probe should not be mounted where it is likely to be splashed with water nor should it be mounted such that the electrical connecting cable unavoidably passes along or over wiring looms, especially those which carry ignition and/or alternator control cables.

Testing

Wheel mounted probes – Terratrip 1

Test the voltage across 'P-' and 'P+'. The voltage should be approximately 5 volt. Touch the end of the probe with a piece of metal, the probe voltage should rise by approximately 0.5 volts.

Wheel mounted probes T202/303

Wheel mounted probes: Test the voltage across 'P-' and 'P+'. The voltage should be approximately 8 volt. Touch the end of the probe with a piece of metal, the probe voltage should rise by approximately 1.0 volt.

Speedometer probes – all models

Test the voltage across 'OV' and 'P+'; this should be approximately 5 volts. Test the voltage across 'OV' and 'P-'; the voltage should vary between approximately 0 volts and 0.45 volts when the speedometer cable is turned slowly.

Conclusions

If you have the correct probe voltage and the voltage rise then the probe is okay.

If you have the voltage but not the voltage rise then the probe is faulty.

If you have no voltage across the probe then the tripmeter is faulty.

Note – Terratrip 1

If you have two 'P+' terminals, one will be live when the 1/0/2 switch is at '1' and the other 'P+' terminal live when the 1/0/2 switch is at '2'.

Cable length

The length of probe may be shortened or lengthened to suit your application. It is *best* to adjust the cable length so that it is just long enough to reach the tripmeter. Loops of cable may pick up interference (see later section).

Displays – cleaning

From time to time the displays may become dusty. Clean the displays using an anti-static cleaner (e.g. record cleaner cloth). Never spray cleaner directly onto the displays – spray onto a lint-free cloth and use the now damp cloth to clean the displays.

Displays – illumination

The bulbs used for night time illumination of LCD displays are 14 volt wire ended. Bulbs of greater wattage must not be fitted otherwise permanent damage may be caused to the displays.

Internal reserve power (IRS) Terratrip 1 only

The IRS is an integral and necessary part of the electronic system. The IRS must be kept in a charged state at all times. The following guidelines will be of assistance.

- (a) Always switch off the tripmeter electronics using switch on the tripmeter if the car battery is to be switched off for more than 20 minutes, e.g. when car in Parc Ferme for more than 24 hours or after rally.
- (b) The power supply can be taken direct from the car battery. If this is done then you **must** fit a 'line fuse' directly after the battery. Switch off the displays when the tripmeter is not in use for longer than 24 hours.
- (c) If the IRS becomes completely discharged, as it would become if the tripmeter were to be left on for more than one hour without the car battery supply being connected, the following operation must be carried out:
 - (i) Connect the tripmeter to a 12 volt car battery and leave displays of tripmeter on for **at least 2 hours**.
 - (ii) Disconnect car battery from tripmeter and **as soon as** the displays start to fade or disappear switch off the tripmeter electronics using the electronics on/off switch.
 - (iii) Reconnect car battery to tripmeter.
 - (iv) Repeat steps (i), (ii), (iii) until IRS will keep tripmeter displays operating for at least 11/2 minutes. The tripmeter may now be left connected to the car battery for 24 hours to fully recharge the IRS.

Note

- (1) The number of times taken to complete the above will be greatly reduced if the car battery is connected to a battery charger.
- (2) The charge/discharge operations detailed above are not necessary when the IRS is used under normal conditions, i.e. to support the tripmeter when changing the car battery. In this case the IRS will automatically recharge properly as long as it has not been allowed to completely discharge (i.e. to zero volts).
- (3) The IRS is a nickel Cadmium re-chargeable battery (Berec SB 1166 or equivalent). **No other type of battery may be used, or serious damage may occur.**

Instrument Malfunctions

If your instrument malfunctions you can be 99.9% sure that the problem is caused by interference, only rarely is the instrument at fault. It is our experience that the usual cause of interference is spark plug leads and ignition coil/distributor lead. In cases of persistent interference we strongly recommend that you use Lucas 'Speedlead' for the plug and distributor/ignition coil leads. If you cannot get the leads locally contact Lucas Competitions Department. Telephone 0121 236 5050. Most times though you can cure interference problems by careful installation.

Interference manifests itself as follows:

1. Distance displays count when car stationary with the engine running.
2. Distance displays shows different readings to each other.
- *3. Displays freeze and tripmeter controls have no effect.
- *4. Displays freeze and show incomplete numbers.
- *5. Tripmeter zeros or malfunctions when car 'yumps' but tapping case of tripmeter when car stationary does not make instrument malfunction.
6. Displays 'flash' occasionally.

*In these cases the only way to get the displays to operate properly is to switch off the electronics and wait for 5-10 seconds before switching electronics on. If the displays are left on when they are 'frozen' then the optics will be permanently damaged. The displays can be replaced but this is not a warranty claim, i.e. we will make a charge for the work.

Areas of interference may be:

Ignition circuits, alternator circuits, fuel pumps, relays, windshield motors, fan motors, etc.

We have found the following installation to be successful:

Power cable:

- (a) **For rear mounted car battery, run power cable through bulkhead, avoiding all electrical apparatus and looms, up to the roll cage, along top of roll cage, down the windscreen pillar section of roll cage, along the front of the dashboard (not behind where it may pick up interference from other wiring looms) and then straight into tripmeter.**
- (b) **For front mounted batteries run cable either towards front of car, or straight through inner wing. In both cases now run cable inside wheel arch (protect cable with plastic tubing), through panel between outer wing and doorpost, through or round doorpost, along front of dashboard and straight into tripmeter.**

Note: A line fuse must be used immediately after the battery.

Probe cables: Pass nearside (kerbside) probe lead from wheel into inner wing. Then follow route as per Power Cable (b) route. Pass offside probe lead either forward and then across front of car to join up with nearside probe lead or along wheel arch through small panel between outer wing and doorpost, through or round doorpost along **top** of dashboard and then straight into tripmeter.

The principles of the above are:

- (a) Avoid **all** other wiring looms and electrical equipment inside car and behind dashboard.
- (b) Avoid running tripmeter cables through engine compartment.
- (c) Keep all cables neat and tidy and cut off any excess cable.

Interference may be transmitted into the instrument via:

Remote Zeroing Unit	– 1st Suspect
Probe Cable(s)	– 2nd Suspect
Power Feed	– 3rd Suspect

To identify the cause of interference:

- (a) Remove RZU – interference ceased? If yes, re-route RZU cable. If not, see (b).
- (b) Remove probe lead(s) – has interference ceased? If yes, re-connect one probe and see if interference re-occurs, re-route cable. Disconnect probe and connect other probe. If interference re-occurs re-route cable.
- (c) If interference is not cured by (a) or (b) re-route power cable and/or fit one microfarad capacitor across +12v and 0v terminals.

In rare cases it may be necessary to fit screened (shielded) cable for the probe and power leads. You should use 2 core cable. Cut probe cable about 2 inches (50mm) from the probe and joint on the screen cable; the joints must be soldered and adequately insulated. The screens of the cable should be earthed at only one end of each cable; this may be done by joining the screens of probe(s) and power cables at the tripmeter and insulate the joint. The screen of the power cable is then earthed at the car battery negative terminal or where the earth strap from the battery is connected to the car body.

That is the bad news. The good news is that the majority of installations do not suffer from interference. When you install your instrument we recommend that you put in your cables on a temporary basis and **do** a proper final installation when you are satisfied that the tripmeter works properly.

You are always welcome to write, telephone or fax for advice. UK customers are welcome, subject to prior appointment, to come to our premises for assistance should they so wish.